

Monitor Series paddle wheel flowmeters provide stable and repeatable flow indication for low, medium and high flow rates in aggressive and ultra pure applications. Non-intrusive sensing provides a pulsed signal to electronic read-outs and controls.

Flow ranges from 0.04 - 0.350 l/min. through 3.00 - 50.00 l/min. in H₂O

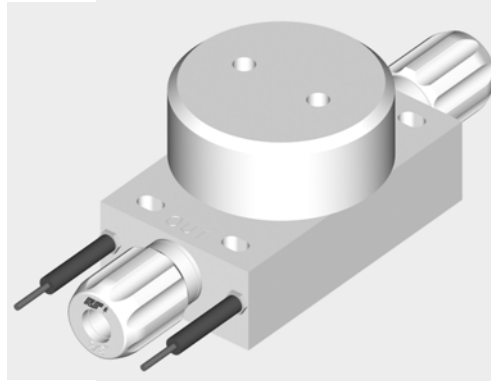

Monitor™ Paddle Wheel

Accurate, Reliable and Repeatable Performance

- 100% functional testing including calibration for accuracy and pressure leak testing—superior performance
- Low sensitivity to viscosity and density—allows for single flowmeter for various applications
- Compact size and orientation flexibility—eases installation in space-limited areas
- Remote installation of controls—isolates operators from hazardous chemicals
- Serialization—quality control tracking and custom configurations

Ultra Pure Construction

- Premium grade fluoropolymers and other high performance plastics—resist corrosion and prevent process contamination
- No exposed metal—eliminates metallic corrosion
- CTFE shaft and bearings—limit potential contamination
- Cleanroom manufacturing and packaging—minimizes potential contamination

f l o w m e t e r s

Operation

Monitor series paddle wheel flowmeters consist of a paddle wheel located in the flow path of the flowmeter. As the fluid flow causes the paddle wheel to rotate, its blades interrupt a light beam sent across the flow path. This generates an electronic, pulsed signal suitable for use with electronic read-outs and controls. Included is the fiber optic amplifier along with six feet of cable.

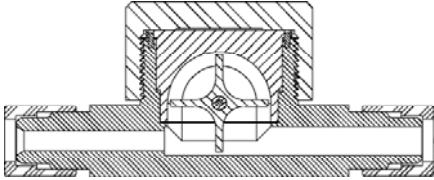

Specifications

MATERIALS

- Wetted parts:
PTFE and CTFE

OPERATING

- Accuracy: $\pm 1\%$ full scale
- Maximum temp: 80°C (176°F)
- Maximum pressure: 100 psi

ELECTRICAL

- Input power: 10-30 VDC at 25 mA
- Output: pulsed solid state NPN
(current sinking)
- Optional PNP Output, contact factory

Configuration Options

CONNECTION SIZES

- 1/4", 3/8", 1/2" and 3/4" fine thread flare

SHAFT AND BEARINGS

- CTFE material

Sensor Specifications

FIBER OPTIC AMPLIFIER CABLE

2 m (6.5') FEP Encapsulated

SUPPLY VOLTAGE & CURRENT

10-30V dc @ 25 mA

OUTPUT TYPE

NPN SOLID STATE / OPTIONAL PNP SOLID STATE (contact factory)

OUTPUT CONFIGURATION

N.O. / N.C. SOLID STATE dc

OUTPUT RESPONSE

1 MILLISECOND / 1 MICROSECOND

ADJUSTMENTS

SENSITIVITY CONTROL, SINGLE-TURN, O-RING SEALED POTENTIOMETER

INDICATORS

GREEN ON STEADILY = dc POWER "ON"

GREEN FLASHING = OUTPUT OVERLOAD

YELLOW ON STEADILY = LIGHT IS SENSED

YELLOW FLASHING = MARGINAL EXCESS GAIN

CONSTRUCTION

YELLOW & BLACK ABS HOUSING, W/ ACRYLIC LENSES TOTALLY SEALED

CONNECTIONS

PVC JACKETED 4-CONDUCTOR 2 M (6.5')

OPERATING CONDITIONS

TEMPERATURE: -4° - 131°F (-20°C - 55°C)

Ordering Information

To order, select a configuration and a flow range from the following tables.
Contact Futurestar for information on additional flow ranges and custom configurations.

FLOW (l/min.)	CONNECTION SIZE	PART NUMBER
0.04 - 0.35	1/4" fine thread flare	5A0-0035-4F
0.10 - 1.00	1/4" fine thread flare	5A0-010-4F
0.30 - 3.00	3/8" fine thread flare	5A0-030-6F
0.5 - 5.00	3/8" fine thread flare	5A0-050-6F
1.00 - 9.00	1/2" fine thread flare	5A0-090-8F
1.5 - 20.00	3/4" fine thread flare	5A0-200-12F
3.00 - 50.00	3/4" fine thread flare	5A0-500-12F

OPTIONAL DISPLAYS AND ACCESSORIES

Optional displays and accessories are ordered separately.
Contact Futurestar for more information.

	DESCRIPTION	PART NUMBER
DISPLAYS CE Compliant	Display Option A <ul style="list-style-type: none"> 6 digit LED display with 4 ½ digit resolution, linearization and totalization Power: 115 VAC 	420-011
	Display Option B <ul style="list-style-type: none"> 6 digit LED display with 4 ½ digit resolution, linearization and totalization Controller 1: Two 5 amp relays Controller 2: 4-20 mA output Power: 115 VAC 	420-012
	Display Option C <ul style="list-style-type: none"> Frequency to Analog Converter DIN-RAIL Mounting Power: 9-32 VDC; 2.5 W Output signal: 4-20 mA, 0-20 mA, 0-5 VDC, 0-10 VDC Sensor input signal: 12 VDC (NPN, PNP) 	420-014
ACCESSORIES	Power Supply <ul style="list-style-type: none"> 12 volt 	430-001
	Serial Communications	Contact Futurestar

Installation Drawings

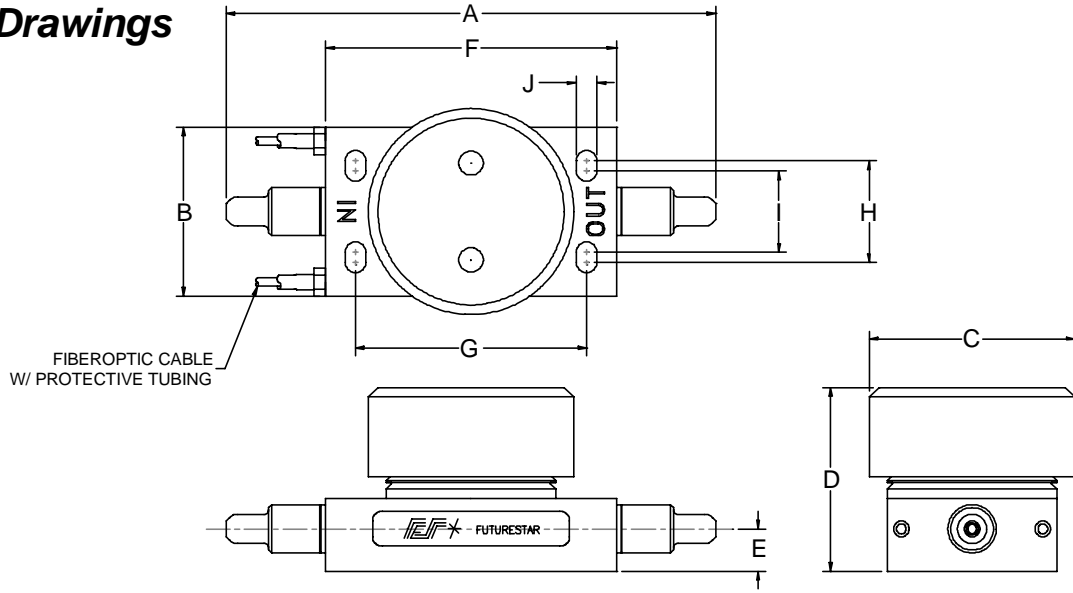

MONTIOR PART NUMBER														
	5A0-0035-4F		5A0-010-4F		5A0-030-6F		5A0-050-6F		5A0-090-8F		5A0-200-12F		5A0-500-12F	
	inches	mm	inches	mm	inches	mm	inches	mm	inches	mm	inches	mm	inches	mm
A	5.06	128.5	5.06	128.5	5.20	132.1	5.20	132.1	5.86	148.8	7.06	179.3	7.06	179.3
B	1.50	38.1	1.75	44.5	1.75	44.5	1.75	44.5	2.00	50.8	2.75	69.9	2.75	69.9
C	1.88	47.8	2.13	54.0	2.13	54.0	2.13	54.0	2.38	60.3	3.13	79.4	3.13	79.4
D	1.84	46.7	1.90	48.3	1.97	50.0	1.97	50.0	2.09	53.1	2.64	67.1	2.64	67.1
E	0.44	11.2	0.44	11.1	0.50	12.7	0.50	12.7	0.56	14.3	0.69	17.5	0.69	17.5
F	3.00	76.2	3.00	76.2	3.00	76.2	3.00	76.2	3.50	88.9	4.50	114.3	4.50	114.3
G	2.38	60.3	2.39	60.7	2.39	60.6	2.39	60.6	2.89	73.4	3.88	98.4	3.88	98.4
H	0.75	19.1	1.05	26.7	1.03	26.1	1.03	26.1	1.25	31.8	2.00	50.8	2.00	50.8
I	0.54	13.7	0.84	21.3	0.82	20.7	0.82	20.7	1.04	26.4	1.79	45.5	1.79	45.5
J	0.21	5.4	0.21	5.4	0.21	5.4	0.21	5.4	0.21	5.4	0.21	5.4	0.21	5.4

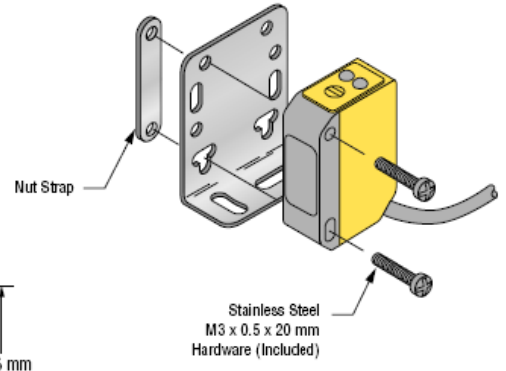
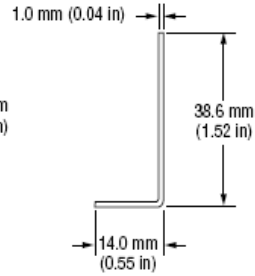
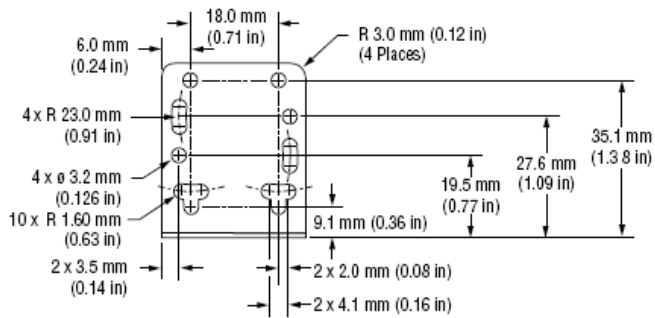
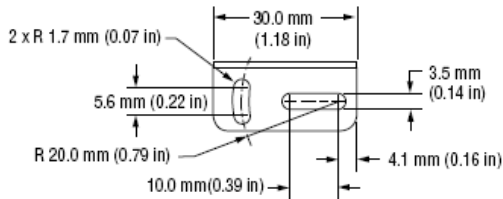

NOTE: Use of lockwashers is optional

